

Spiral Wound Gasket for Ultrahigh-temperature Use TOMBO™ No.1838R-NM “Vortex® Gasket-NM”

Industrial Products Division

Piping / Equipment Parts Technology Development Department

1. Introduction

Gaskets are fastened to flanges to prevent fluid leakage from pipes or equipment parts. They are important parts that support stable operations in many industries, including petroleum refining, petrochemicals, shipbuilding, electric power, and steel. Gaskets are classified by the type, pressure, and temperature of the fluid flowing through pipes or equipment parts. In July 2019, NICHIAS added

the spiral wound gasket TOMBO™ No.1838R-NM Vortex® Gasket-NM (hereafter “Vortex-NM”) to its lineup. This gasket can be used in the ultrahigh-temperature range of up to 1000°C (Figure 1). The Vortex-NM filler is oxidation-resistant, originally developed by NICHIAS, and has excellent sealing properties compared to conventional oxidation-resistant fillers.

This report introduces the main features of Vortex-NM.

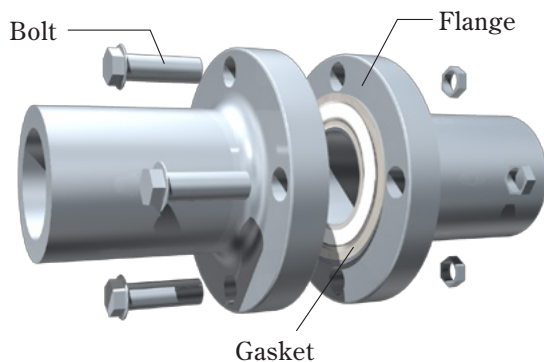
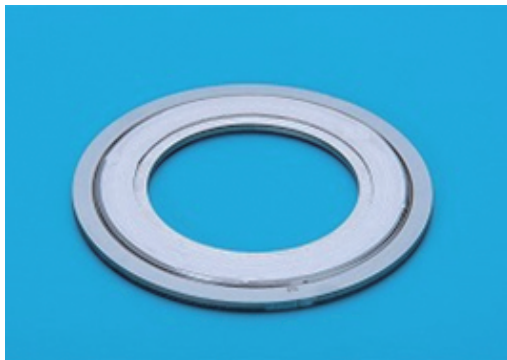

Figure 1 Appearance of Vortex-NM and image of flange use

2. What is the Vortex® Gasket?

The Vortex® Gasket comprises of ‘hoop’ or steel strips and ‘filler’ or cushion material alternately stacked and wound in a spiral shape. It is widely used for pipes or equipment intended for high temperatures and pressures (Figure 2). The filler types include expanded graphite and mica which are selected according to the target usage conditions (Table 1).

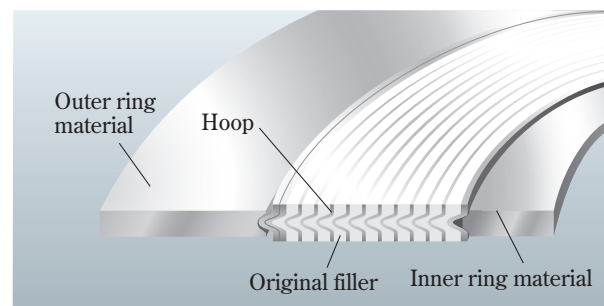

Figure 2 Cross section of Vortex-NM

Table 1 Lineup of Vortex® gaskets and their features

Name	Application	Maximum allowable working temperature	Filler	Features
[New product] Vortex-NM	Ultra-high-temperature use	1000°C	Original filler	<ul style="list-style-type: none"> ○ The filler is stable up to 1000°C. ○ Can be used at ultrahigh temperatures where conventional products cannot be used. ○ Excellent sealing and compression/restoration properties.
Vortex-GH	High-temperature use	800°C	Expanded graphite and mica	<ul style="list-style-type: none"> ○ Can be used at high temperatures up to 800°C. × Depending on the conditions, expanded graphite may be oxidized.
Vortex-GR	General purpose	450°C	Expanded graphite	<ul style="list-style-type: none"> ○ Excellent sealing and compression/restoration properties. × Cannot be used at temperatures exceeding 450°C.

The GRASEAL® Vortex® Gasket (hereafter “Vortex-GR”), which uses expanded graphite for the filler, is used in a wide range of applications because of its excellent sealing and compression/restoration properties. This gasket cannot be used in temperatures exceeding 450°C or in oxidizing fluids, such as molten salt, because the expanded graphite is oxidized, destroying the sealing function.

Gaskets of composite types such as Vortex-GH are used in conditions like the above, where the oxidization of expanded graphite is suppressed by the mica filler wound around the inner and outer peripheries. Gaskets of composite types can suppress, but not completely prevent, the oxidization of expanded graphite; therefore, there are conditions under which these gaskets cannot be used.

3. Outline of Vortex-NM

The new product, Vortex-NM, maintains a long stable sealing performance in high-temperature conditions where conventional Vortex gaskets cannot be used. The Vortex-NM filler is an original product developed by NICHIAS. It has both excellent sealing and oxidation resistance properties. In addition, it is patent pending.

Table 2 summarizes Vortex-NM product specifications. This gasket also passed the API Standard 6FB, Third Edition fire test. Thus verifying

Table 2 Vortex-NM product specifications

Maximum allowable working temperature ^(Note 1)	°C	1000	
Maximum allowable working pressure ^(Note 1)	MPa	Water- or oil-based fluid	43
		Gas-based fluid	26
Main body thickness	mm	4.5	
Maximum nominal diameter ^(Note 2)	—	24B	
Gasket coefficient m	—	3.00	
Minimum designed seating stress y	N/mm ²	68.9	
Minimum seating surface pressure σ_s	N/mm ²	Water- or oil-based fluid	34.3
		Gas-based fluid	78.4
Allowable seating surface pressure	N/mm ²	294.2	
API Standard 6FB, Third Edition		Passed	

Note 1: The maximum operating temperature and pressure indicate their own individual application limits.

Note 2: For dimensions above 24B, contact NICHIAS.

that the gasket function is unlikely to degrade and that leakage due to a fire is unlikely.

4. Product features

The room-temperature sealing and compression/restoration properties of Vortex-NM are equivalent to those of Vortex-GR, which is used in a wide range of applications because of its excellent

properties. In addition, because of the excellent oxidation resistance of the filler, Vortex-NM can also be used for ultrahigh-temperature ranges of up to 1000°C and in molten salt which is strongly oxidizing (heat transfer salt, hereafter “HTS”). The details of the characteristic evaluations are as follows.

4.1 Room-temperature sealing and compression/restoration properties (JIS B 2490 pipe flange gasket sealing property test)

The sealing property test at room temperature of a gasket for pipe flanges with internal pressure is specified in JIS standards. In the JIS test, the gasket seating stress is changed step-by-step and the basic leakage amount and compression deformation amounts are measured. Figure 3 shows the test conditions and the gasket sealing pressure sequence.

Test conditions

Dimensions	JIS 20K 50A
Fluid	Helium
Internal pressure	4 MPa
Leakage measurement method	Soap-film flow meter and helium leak detector

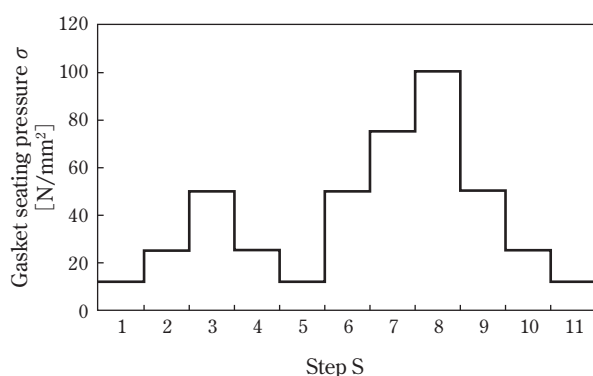

Figure 3 JIS B 2490 test conditions and gasket seating pressure sequence

4.1.1 Room-temperature sealing properties

Before operation is started in a plant or equipment, an airtight test may be conducted using soap water in order to check for leaks in piping lines by checking for foaming of the soap water.

Sealing at room temperature is thus another important property. The pass judgment criterion in the airtight test was defined as the detection limit for the soap water foaming method (i.e. $3 \times 10^{-4} \text{ Pa} \cdot \text{m}^3/\text{s}$), which sprays soap water on pipes and detects leaks by the presence of foaming. The required seating stress to pass the test was then compared with Vortex-GR.

Figure 4 shows the test results. In Step 3, Vortex-NM reached a leakage that passed the airtight test, which was equivalent to Vortex-GR.

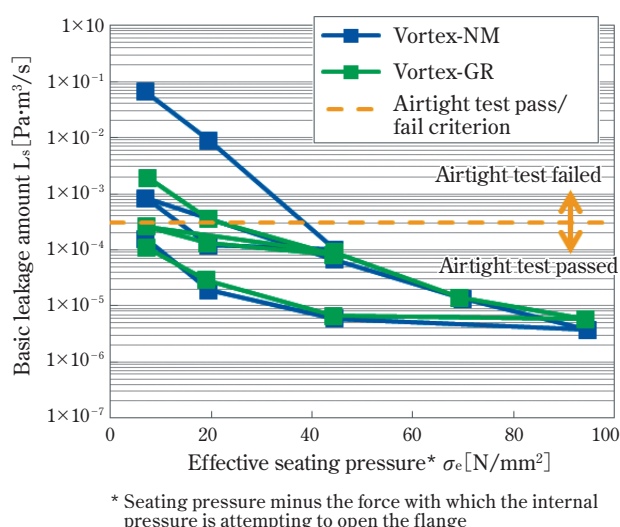

Figure 4 Results of JIS B 2490 (Test method for sealing behavior of gaskets for pipe flanges) (Room-temperature sealing property)

4.1.2 Compression/restoration property

The compression/restoration property is another important characteristic for gaskets. The larger the compression, the more irregularities are absorbed on the flange surface, thus securing better sealing. In addition, the greater the restoration, the better it can follow the opening of the flange during operation, maintaining the sealing. Figure 5 shows the relationship between the effective seating pressure and gasket compressive deformation amount. It shows that Vortex-NM is equivalent to or greater than Vortex-GR in the number of compression Steps 1 to 8 and the decompression Steps 8 to 11.

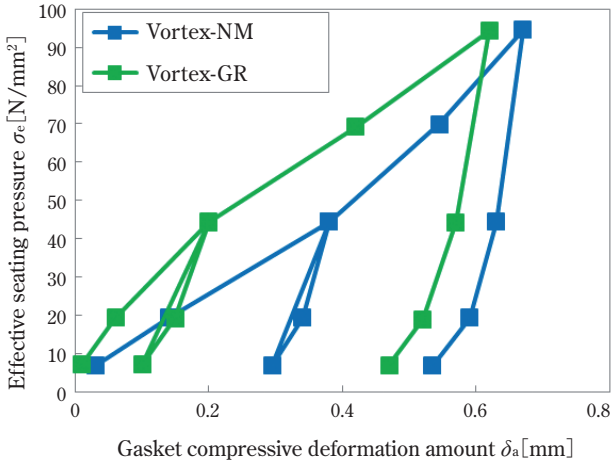

Figure 5 Results of JIS B 2490 (Test method for sealing behavior of gaskets for pipe flanges) (Compression/restoration property)

4.2 Heating cycle sealing property

Gaskets are more prone to leakage due to loose bolts when the operation is at a standstill (i.e. the flange fastened section is cooled) than during operation when they are continually heated. Thus, in order to evaluate the heat-resistant sealability of the gasket, a heating cycle seal test of repeated heating to 1000°C and cooling to room temperature was conducted. Afterwards it was compared with oxidation-resistant filler product A, which was a conventional product manufactured by a competitor (hereafter “Competitor Product A”). Figure 6 shows the test conditions and the heating program. At an ultrahigh temperature of 1000°C, the seating surface pressure of the gasket decreases due to relaxation of the bolt stress. By inserting a spacer between bolts to mitigate this effect, adjustment was made so that the specified surface pressure would be applied to the gasket even if the bolts relaxed.

Figure 7 shows a chart of the leakage amounts in the respective cycles. The leakage amount of Competitor Product A increased due to heating, making it unmeasurable, whereas Vortex-NM demonstrated stable sealing without increasing the leakage amount even during a 1000°C heating cycle.

Test conditions

Steel material	Inconel 600
Dimensions	JPI class 300 2B
Seating pressure	78.4N/mm ² (flange inner -surface control with spacer)
Fluid	Nitrogen
Internal pressure	1 MPa
Leakage measurement method	Pressure drop method and mass flow meter

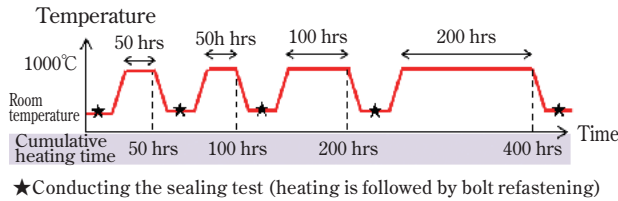
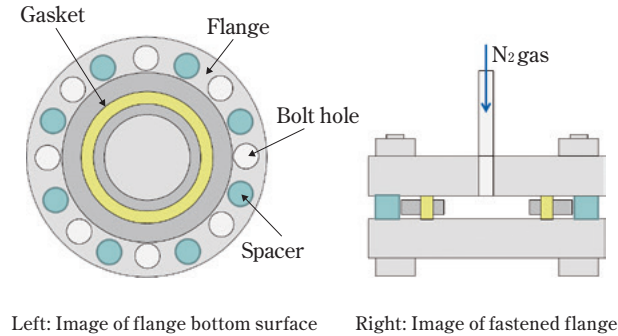

Figure 6 Test conditions and heating program

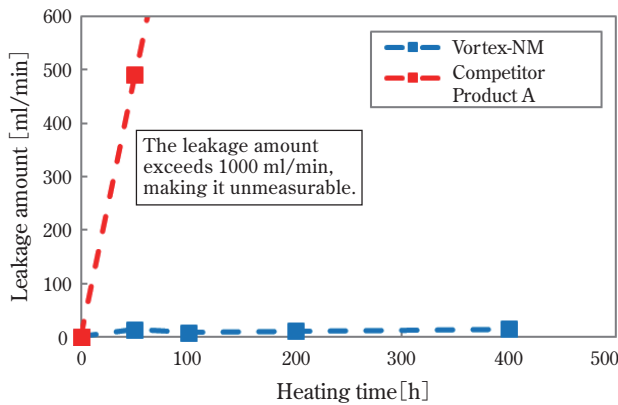
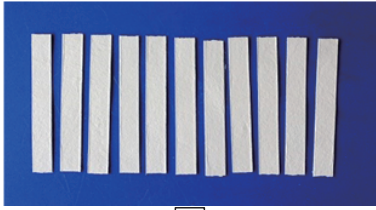



Figure 7 Results of heating cycle sealing test

4.3 HTS resistance

HTS, a strongly oxidizing fluid, causes expanded graphite filler to disappear independently of the fluid temperature. Thus Vortex-GR cannot be used for HTS. Vortex-NM, however, can be used for

Product name	Vortex-NM	Vortex-GR
Filler	Original filler	Expanded graphite filler
Before immersion		
After 200 hrs immersion at 450°C		Disappears and cannot be recovered
Weight reduction rate[%]	5	Unmeasurable due to disappearance

Test conditions

HTS	Sodium nitrite 40 wt%
	Sodium nitrate 7 wt%
	Potassium nitrate 53 wt%
Immersion conditions	450°C × 200 hrs

Figure 8 HTS immersion test results (*immersion test of filler alone)

such fluids. In order to evaluate the HTS resistance, the original Vortex-NM filler and the Vortex-GR filler were immersed in HTS at 450°C for 200 hours before the fillers' weight reduction rates were measured. **Figure 8** shows the test results. After testing, the expanded graphite filler disappeared completely, whereas the original filler neither oxidized nor disappeared and only exhibited binder-derived weight reduction. This demonstrates that the Vortex-NM filler is resistant to HTS.

5. Conclusion

This report introduced the spiral wound gasket Vortex® Gasket-NM, which can be used in the ultrahigh-temperature range of up to 1000°C. Vortex-NM is a new spiral wound gasket with significantly improved sealing compared to conventional oxidation-resistant fillers. Vortex-NM can be used

for a long period of time both at ultrahigh temperature and for HTS which cause oxidization to expanded graphite filler.

We will continue to develop products that meet customer needs. We welcome your feedback and requests.

For inquiries or questions about this product, please contact the Piping / Equipment Parts Technology Development Department of the Industrial Products Division.

*TOMBO is a trademark or registered trademark of NICHIAS Corporation.

*GRASEAL and Vortex are registered trademarks of NICHIAS Corporation.

*The measurements presented in this report should be used only as a guide and not as guaranteed values.

*Due to the components of the material, this product may generate a trace amount of silicon fluoride gas when heated above 500°C. Please see the SDS for your risk assessment.